

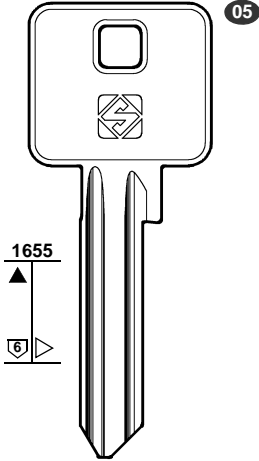

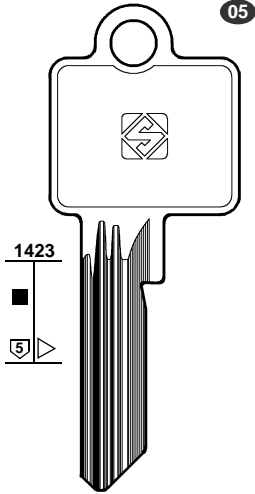
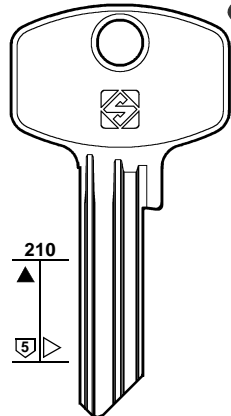
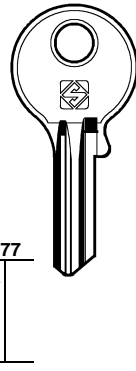
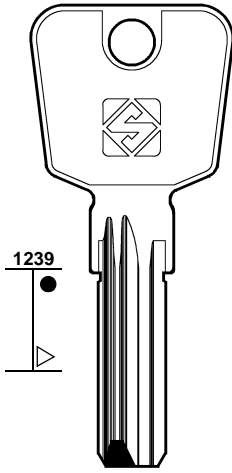

New Keys / Chiavi Nuove / Neue Schlüssel / Nouvelles Clés  
Llaves Nuevas / Chaves Nuevas

FOR: PER:	ABUS	BKS	DOM		FOR / PER
	 <p>05</p> <p>1655</p> <p>6</p> <p>AB98</p>	 <p>05</p> <p>1423</p> <p>5</p> <p>BK52 10</p> <p>BK53 16</p>	 <p>05</p> <p>210</p> <p>5</p> <p>DM152</p>	 <p>04</p> <p>277</p> <p>DM153</p>	ABUS (D) BKS (D) DOM (D) SÜDMETALL (D) TRELOCK (D) WILKA (D)
FOR: PER:	SÜDMETALL	TRELOCK	WILKA		
	 <p>06</p> <p>1239</p> <p>SDT1R</p> 	 <p>04</p> <p>11</p> <p>5</p> <p>TRK9</p> <p>TRK9R</p> 	 <p>05</p> <p>OV</p> <p>5</p> <p>WK62R</p>		

01  
 COMMERCIAL GROUP  
 GRUPPO COMMERCIALE  
 PREISEGRUPPE  
 GROUPE COMMERCIAL  
 GRUPO COMMERCIAL  
 GRUPO COMERCIAL

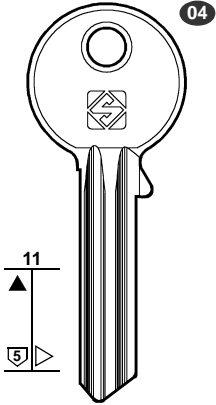
[www.silca.biz](http://www.silca.biz)

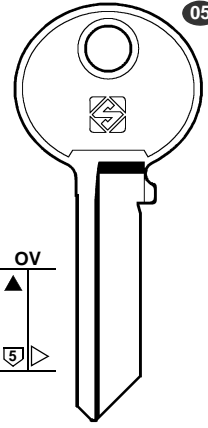
FOR / PER
DAIHATSU (J)
HYUNDAI (ROK)
SSANGYONG (ROK)
TOYOTA (J)
TRW SIPEA (I)

**FOR: DAIHATSU**  
**PER:**

96

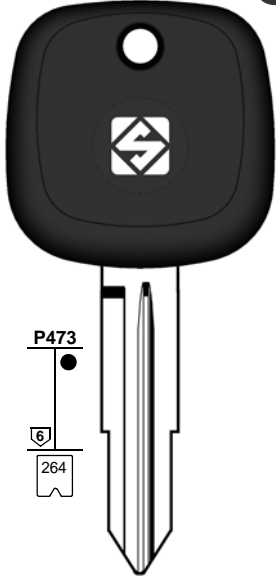

P473



264



**DH5RTE**  
D . . . . 3001-4000



Key with Adapter / without Transponder chip  
Chiave con Adattatore / senza Transponder chip  
Schlüssel mit Adapter / ohne Transponder chip  
Clé avec Adaptateur / sans Transpondeur chip  
Llaves con Adaptador / sin Transponder chip  
Chave com Adaptador / sem Transponder chip

**FOR: HYUNDAI**  
**PER:**

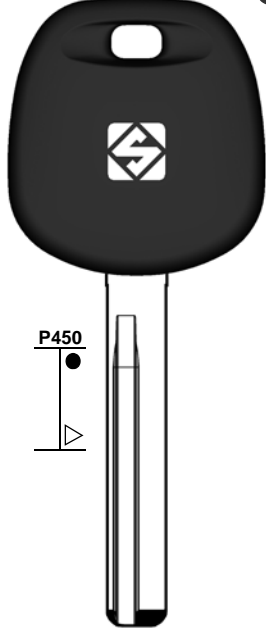
97

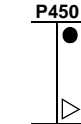

P450





**HYN17BTE**      **HYN17RBTE**

Key with Adapter / without Transponder chip  
Chiave con Adattatore / senza Transponder chip  
Schlüssel mit Adapter / ohne Transponder chip  
Clé avec Adaptateur / sans Transpondeur chip  
Llaves con Adaptador / sin Transponder chip  
Chave com Adaptador / sem Transponder chip

**FOR: SSANGYONG**  
**PER:**

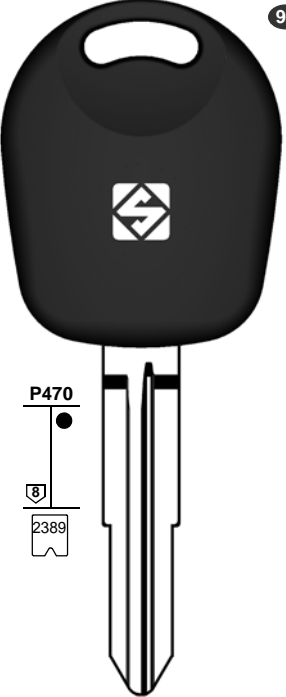
96



P470



2389



**SSY3TE**  
SK . . . . 1-1000  
KH . . . . 1-1000

Key with Adapter / without Transponder chip  
Chiave con Adattatore / senza Transponder chip  
Schlüssel mit Adapter / ohne Transponder chip  
Clé avec Adaptateur / sans Transpondeur chip  
Llaves con Adaptador / sin Transponder chip  
Chave com Adaptador / sem Transponder chip

**FOR: TOYOTA**  
**PER:**

97

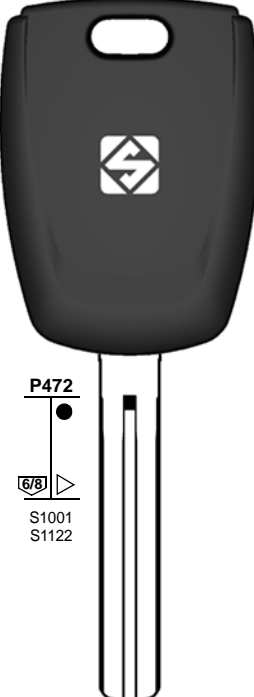

P472



S1001  
S1122



**TOY49TE**  
K . . . . 0001-2500  
P . . . . 0001-2500

Key with Adapter / without Transponder chip  
Chiave con Adattatore / senza Transponder chip  
Schlüssel mit Adapter / ohne Transponder chip  
Clé avec Adaptateur / sans Transpondeur chip  
Llaves con Adaptador / sin Transponder chip  
Chave com Adaptador / sem Transponder chip

**FOR: TRW SIPEA**  
**PER:**

97

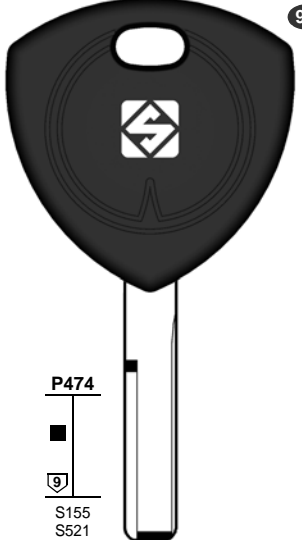

P474



S155  
S521



**SIP16TE**  
. . . . 1-17735  
LA . . . . 1-17735

Key with Adapter / without Transponder chip  
Chiave con Adattatore / senza Transponder chip  
Schlüssel mit Adapter / ohne Transponder chip  
Clé avec Adaptateur / sans Transpondeur chip  
Llaves con Adaptador / sin Transponder chip  
Chave com Adaptador / sem Transponder chip

**01**  
COMMERCIAL GROUP  
GRUPPO COMMERCIALE  
PREISEGRUPPE  
GROUPE COMMERCIAL  
GRUPO COMMERCIAL  
GRUPO COMERCIAL  
[www.silca.biz](http://www.silca.biz)

Car Keys Guide / Guida Chiavi Auto / Marktführer für Autoschlüssel / Guide Clés pour Voitures  
 Guía Llaves para Coches / Guia Chaves para Carros

New Updates

1	2	2a	3	3a	3b	E1+E2		6	42+71	72	43 44a	12	15
						GTI COMPATIBLE		IGNITION					
CAR MAKE MODEL	FROM	TO	SILCA REF.	SILCA REF.	SILCA REF.	COPY	GEN.	TRANSP. TYPE	FAST COPY PLUS RW4 PLUS FAST COPY / RW4	FAST COPY PLUS RW4 PLUS	FAST COPY RW4	STP	

For more info on the uses of car keys, refer to the Silca Electronic Key Catalogue:



### ALFA ROMEO®

166	2000	2004	SIP16MH	SIP16TE	SIP16FH*	Y		PH / CR2	46	Y	P-BOX		
-----	------	------	---------	---------	----------	---	--	----------	----	---	-------	--	--

### DAIHATSU®

CUORE	1998	2006	DH5RMH	DH5RTE	DH5RFH*	Y	Y	TEXAS	4C	Y	P-BOX		
MOVE	1997	2002	DH5RMH	DH5RTE	DH5RFH*	Y	Y	TEXAS	4C	Y	P-BOX		

### HYUNDAI®

ACCENT (AUS)	2012			HYN17BTE		Y		PH / CR2	46	Y	P-BOX		
I20	2008		TOY49MH	TOY49TE	TOY49FH*	Y	Y	PH / CR2	46	Y	P-BOX		
I30	2007	2011	TOY49MH	TOY49TE	TOY49FH*	Y	Y	PH / CR2	46	Y	P-BOX		
I40 (AUS)	2010		TOY49MH	TOY49TE	TOY49FH*	Y	Y	PH / CR2	46	Y	P-BOX		
I45	2009		TOY49MH	TOY49TE	TOY49FH*	Y	Y	PH / CR2	46	Y	P-BOX		
IX20	2010		TOY49MH	TOY49TE	TOY49FH*	Y	Y	PH / CR2	46	Y	P-BOX		
IX35	2010		TOY49MH	TOY49TE	TOY49FH*	Y	Y	PH / CR2	46	Y	P-BOX		
SANTA FE (AUS)	2013			HYN17RBTE		Y		PH / CR2	46	Y	P-BOX		
VELOSTER (AUS)	2012			HYN17BTE		Y		PH / CR2	46	Y	P-BOX		

### KIA®

BORREGO	2009	2011	TOY49MH	TOY49TE	TOY49FH*	Y	Y	PH / CR2	46	Y	P-BOX		
MAGENTIS	2009	2011	TOY49MH	TOY49TE	TOY49FH*	Y	Y	PH / CR2	46	Y	P-BOX		
OPIRUS	2007	2010	TOY49MH	TOY49TE	TOY49FH*	Y	Y	PH / CR2	46	Y	P-BOX		
RIO	2010	2011	TOY49MH	TOY49TE	TOY49FH*	Y	Y	PH / CR2	46	Y	P-BOX		

### SSANGYONG®

ACTYON	2007		SSY3MH	SSY3TE	SSY3FH*	Y	Y	TEX / CR	60	Y	P-BOX		
KYRON	2005		SSY3MH	SSY3TE	SSY3FH*	Y	Y	TEX / CR	60	Y	P-BOX		
REXTON	2006		SSY3MH	SSY3TE	SSY3FH*	Y	Y	TEX / CR	60	Y	P-BOX		



#### IMPORTANT NOTE:

See also the "Vehicle Guide Legend"  
 Vedi anche la "Legenda Guida Veicoli"  
 Siehe auch die "Fahrzeugschlüssel Erläuterung"  
 Voir aussi la "Légende Guide Véhicules"  
 Véase también la "Leyenda Guía para Vehículos"  
 Veja também a "Legenda Guia para Veículos"

\* Blade for "Silca Flip key" plastic head

® are Registered Trademarks

## SILCA EMPTY SHELLS - NEW REFERENCES

 Silca Empty Shells: **4 new keys references** to widen the existing range.

 Silca Empty Shells: **4 nouvelles références** clés qui complètent la gamme existante.

 Silca Empty Shells: **4 nuove referenze** chiavi che implementano la gamma già esistente.

 Silca Empty Shells: **4 nuevas referencias** llaves que completan la gama existente.

 Silca Empty Shells: **4 Schlüssel Referenzen** die das bestehende Angebot implementieren.

 Silca Empty Shells: **4 novas referências** chaves que implementam a gama existente.

Brand	Part Number/Image	Application*/Utilization*	Models*				
			MODELS	YEAR FROM	YEAR TO	TRANSPONDER TYPE	TRP ID
CITROËN® (see also PEUGEOT®)	<b>VA2BRS2</b> 	2 Buttons - Flip	BERLINGO	2008		PH-CR2	46
			C2	2006		PH-CR2	46
CITROËN® (see also PEUGEOT®)	<b>VA2BRS8</b> 	3 Buttons - Flip	C3 PICASSO	2008		PH-CR2	46
			C5	2006	2008	PH-CR2	46
LEXUS® (see also TOYOTA®)	<b>TOYRS8</b> 	Lexus®/Toyota® 3 Buttons - Spare part	<b>Rubber Push Button</b> <b>Spare part for TOY40BRS8, TOY43BRS8, TOY48BRS8 references</b>				

\* The uses of the keys are purely indicative and may be subject to updates and revisions. / Gli utilizzi delle chiavi sono da considerarsi puramente indicativi e possono essere oggetto di aggiornamenti e revisioni. / Die Abbildung und technischen Daten der Schlüssel sind nicht bindend. Silca behält sich Änderungen am Produkt, die zur Verbesserung beitragen, vor. / Les usages des clés sont purement indicatifs; ils peuvent être mis à jour et revus. / Los usos de las llaves deben considerarse puramente indicativos y pueden ser objeto de actualizaciones y revisiones. / As utilizações das chaves devem ser consideradas puramente indicativas e podem ser objecto de actualizações e revisões.

© Registered Trademarks. / © Marchi Registrati. / © Eingetragene Marken. / © Marques Déposées. / © Marcas Registradas. / © Marcas Registradas.

<p>PEUGEOT® (see also CITROËN®)</p>	<p><b>VA2BRS2</b></p> 	<p>2 Buttons - Flip</p>	<table border="1"> <thead> <tr> <th>MODELS</th> <th>YEAR FROM</th> <th>YEAR TO</th> <th>TRANSPONDER TYPE</th> <th>TRP ID</th> </tr> </thead> <tbody> <tr> <td>407</td> <td>2004</td> <td>2008</td> <td>PH-CR2</td> <td>46</td> </tr> </tbody> </table>	MODELS	YEAR FROM	YEAR TO	TRANSPONDER TYPE	TRP ID	407	2004	2008	PH-CR2	46															
MODELS	YEAR FROM	YEAR TO	TRANSPONDER TYPE	TRP ID																								
407	2004	2008	PH-CR2	46																								
<p>PEUGEOT® (see also CITROËN®)</p>	<p><b>VA2BRS8</b></p> 	<p>3 Buttons - Flip</p>	<table border="1"> <thead> <tr> <th>MODELS</th> <th>YEAR FROM</th> <th>YEAR TO</th> <th>TRANSPONDER TYPE</th> <th>TRP ID</th> </tr> </thead> <tbody> <tr> <td>407</td> <td>2008</td> <td>2011</td> <td>PH-CR2</td> <td>46</td> </tr> </tbody> </table>	MODELS	YEAR FROM	YEAR TO	TRANSPONDER TYPE	TRP ID	407	2008	2011	PH-CR2	46															
MODELS	YEAR FROM	YEAR TO	TRANSPONDER TYPE	TRP ID																								
407	2008	2011	PH-CR2	46																								
<p>SEAT® (see also SKODA®, VOLKSWAGEN®)</p>	<p><b>HURSA8</b></p> 	<p>3 Buttons</p>	<table border="1"> <thead> <tr> <th>MODELS</th> <th>YEAR FROM</th> <th>YEAR TO</th> <th>TRANSPONDER TYPE</th> <th>TRP ID</th> </tr> </thead> <tbody> <tr> <td>ALTEA</td> <td>2004</td> <td>2008</td> <td>MEG-CR</td> <td>A3</td> </tr> <tr> <td>ALTEA XL</td> <td>2006</td> <td>2008</td> <td>MEG-CR</td> <td>A3</td> </tr> <tr> <td>LEON</td> <td>2005</td> <td>2008</td> <td>MEG-CR</td> <td>A3</td> </tr> <tr> <td>TOLEDO</td> <td>2005</td> <td>2008</td> <td>MEG-CR</td> <td>A3</td> </tr> </tbody> </table>	MODELS	YEAR FROM	YEAR TO	TRANSPONDER TYPE	TRP ID	ALTEA	2004	2008	MEG-CR	A3	ALTEA XL	2006	2008	MEG-CR	A3	LEON	2005	2008	MEG-CR	A3	TOLEDO	2005	2008	MEG-CR	A3
MODELS	YEAR FROM	YEAR TO	TRANSPONDER TYPE	TRP ID																								
ALTEA	2004	2008	MEG-CR	A3																								
ALTEA XL	2006	2008	MEG-CR	A3																								
LEON	2005	2008	MEG-CR	A3																								
TOLEDO	2005	2008	MEG-CR	A3																								
<p>SKODA® (see also SEAT®, VOLKSWAGEN®)</p>	<p><b>HURSA8</b></p> 	<p>3 Buttons</p>	<table border="1"> <thead> <tr> <th>MODELS</th> <th>YEAR FROM</th> <th>YEAR TO</th> <th>TRANSPONDER TYPE</th> <th>TRP ID</th> </tr> </thead> <tbody> <tr> <td>OCTAVIA</td> <td>2004</td> <td>2006</td> <td>MEG-CR</td> <td>A4</td> </tr> <tr> <td>ROOMSTER</td> <td>2006</td> <td>2008</td> <td>MEG-CR</td> <td>A4</td> </tr> <tr> <td>ROOMSTER SCOUT</td> <td>2007</td> <td>2008</td> <td>MEG-CR</td> <td>A4</td> </tr> </tbody> </table>	MODELS	YEAR FROM	YEAR TO	TRANSPONDER TYPE	TRP ID	OCTAVIA	2004	2006	MEG-CR	A4	ROOMSTER	2006	2008	MEG-CR	A4	ROOMSTER SCOUT	2007	2008	MEG-CR	A4					
MODELS	YEAR FROM	YEAR TO	TRANSPONDER TYPE	TRP ID																								
OCTAVIA	2004	2006	MEG-CR	A4																								
ROOMSTER	2006	2008	MEG-CR	A4																								
ROOMSTER SCOUT	2007	2008	MEG-CR	A4																								

\* The uses of the keys are purely indicative and may be subject to updates and revisions. / Gli utilizzi delle chiavi sono da considerarsi puramente indicativi e possono essere oggetto di aggiornamenti e revisioni. / Die Abbildung und technischen Daten der Schlüssel sind nicht bindend. Silca behält sich Änderungen am Produkt, die zur Verbesserung beitragen, vor. / Les usages des clés sont purement indicatifs; ils peuvent être mis à jour et revus. / Los usos de las llaves deben considerarse puramente indicativos y pueden ser objeto de actualizaciones y revisiones. / As utilizações das chaves devem ser consideradas puramente indicativas e podem ser objecto de actualizações e revisões.

® Registered Trademarks. / ® Marchi Registrati. / ® Eingetragene Marken. / ® Marques Déposées. / ® Marcas Registradas. / ® Marcas Registradas.

<p>TOYOTA® (see also LEXUS®)</p>	<p><b>TOYRS8</b></p> 	<p>Lexus®/Toyota® 3 Buttons - Spare part</p>	<p><b>Rubber Push Button</b> Spare part for TOY40BRS8, TOY43BRS8, TOY48BRS8 references</p>																																								
<p>VOLKSWAGEN® (see also SEAT®, SKODA®)</p>	<p><b>HURSA8</b></p> 	<p>3 Buttons</p>	<table border="1"> <thead> <tr> <th>MODELS</th> <th>YEAR FROM</th> <th>YEAR TO</th> <th>TRANSPONDER TYPE</th> <th>TRP ID</th> </tr> </thead> <tbody> <tr> <td>CROSS GOLF</td> <td>2006</td> <td>2007</td> <td>MEG-CR</td> <td>A1</td> </tr> <tr> <td>EOS</td> <td>2006</td> <td>2007</td> <td>MEG-CR</td> <td>A1</td> </tr> <tr> <td>GOLF</td> <td>2004</td> <td>2008</td> <td>MEG-CR</td> <td>A1</td> </tr> <tr> <td>INDIVIDUAL</td> <td>2004</td> <td>2008</td> <td>MEG-CR</td> <td>A1</td> </tr> <tr> <td>JETTA</td> <td>2004</td> <td>2007</td> <td>MEG-CR</td> <td>A1</td> </tr> <tr> <td>PASSAT</td> <td>2004</td> <td>2005</td> <td>MEG-CR</td> <td>A1</td> </tr> <tr> <td>TOURAN</td> <td>2003</td> <td>2007</td> <td>MEG-CR</td> <td>A1</td> </tr> </tbody> </table>	MODELS	YEAR FROM	YEAR TO	TRANSPONDER TYPE	TRP ID	CROSS GOLF	2006	2007	MEG-CR	A1	EOS	2006	2007	MEG-CR	A1	GOLF	2004	2008	MEG-CR	A1	INDIVIDUAL	2004	2008	MEG-CR	A1	JETTA	2004	2007	MEG-CR	A1	PASSAT	2004	2005	MEG-CR	A1	TOURAN	2003	2007	MEG-CR	A1
MODELS	YEAR FROM	YEAR TO	TRANSPONDER TYPE	TRP ID																																							
CROSS GOLF	2006	2007	MEG-CR	A1																																							
EOS	2006	2007	MEG-CR	A1																																							
GOLF	2004	2008	MEG-CR	A1																																							
INDIVIDUAL	2004	2008	MEG-CR	A1																																							
JETTA	2004	2007	MEG-CR	A1																																							
PASSAT	2004	2005	MEG-CR	A1																																							
TOURAN	2003	2007	MEG-CR	A1																																							

\* The uses of the keys are purely indicative and may be subject to updates and revisions. / Gli utilizzi delle chiavi sono da considerarsi puramente indicativi e possono essere oggetto di aggiornamenti e revisioni. / Die Abbildung und technischen Daten der Schlüssel sind nicht bindend. Silca behält sich Änderungen am Produkt, die zur Verbesserung beitragen, vor. / Les usages des clés sont purement indicatifs; ils peuvent être mis à jour et revus. / Los usos de las llaves deben considerarse puramente indicativos y pueden ser objeto de actualizaciones y revisiones. / As utilizações das chaves devem ser consideradas puramente indicativas e podem ser objecto de actualizações e revisões.

© Registered Trademarks. / © Marchi Registrati. / © Eingetragene Marken. / © Marques Déposées. / © Marcas Registradas. / © Marcas Registradas.

## Transponder T33

### 🇬🇧 Transponder T33

Boost your automotive keys service with Silca's new T33 rewritable glass transponder, that will allow you to copy Megamos® Crypto type transponders (ID48-A and ID48-K) for the most popular Chevrolet-Daewoo®, Kia® and Pontiac® vehicle models. T33 is a reliable CE-certified solution, guaranteed by Silca.

### 🇮🇹 Transponder T33

Amplia il tuo servizio chiavi automotive con il nuovo transponder riscrivibile in vetro Silca T33, che ti permetterà di copiare transponder di tipo Megamos® Crypto (ID48-A e ID48-K) per i modelli Chevrolet- Daewoo®, Kia® e Pontiac® più diffusi. T33 è una soluzione affidabile e di alta qualità certificata a marchio CE e garantita da Silca.

### 🇩🇪 Transponder T33

Erweitern Sie Ihren Autoschlüsseldienst mit dem neuen wiederbeschreibbaren Glas-Transponder Silca T33, der es Ihnen ermöglicht, Transponder des Typs Megamos® Crypto (ID48-A und ID48-K) für die wichtigsten Modelle von Chevrolet-Daewoo®, Kia® und Pontiac® zu kopieren. Mit dem T33 erhalten Sie eine zuverlässige Lösung von hoher Qualität, die durch das CE-Zeichen bestätigt und von Silca garantiert wird.

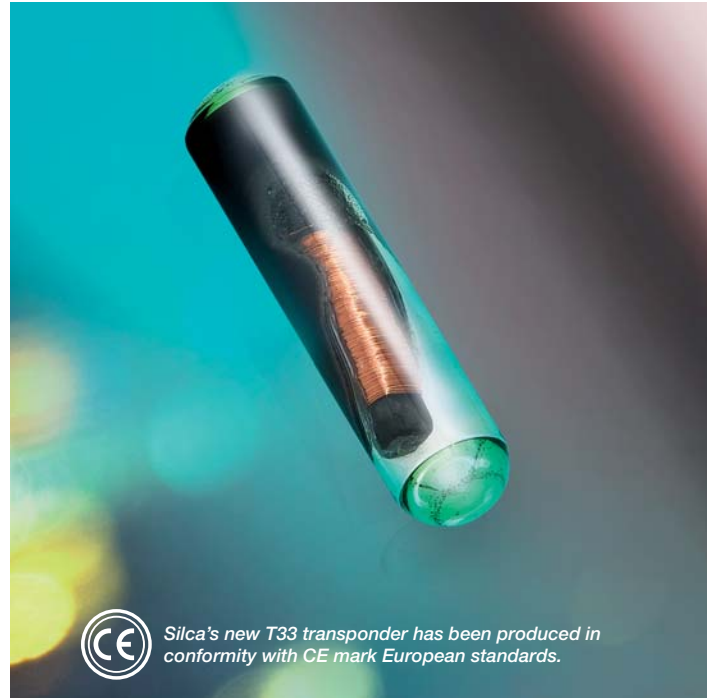

Silca's new T33 transponder has been produced in conformity with CE mark European standards.

### 🇫🇷 Transpondeur T33

Renforcez votre service de clés automobiles avec le nouveau transpondeur réinscriptible en verre T33 de Silca. Ce dispositif vous permettra de reproduire les transpondeurs de type Megamos® Crypto (ID48-A et ID48-K) pour la plupart des modèles de véhicules des marques Chevrolet-Daewoo®, Kia® et Pontiac®. Le transpondeur T33 est une solution fiable et de haute qualité certifiée par le marquage CE et garantie par Silca.

### 🇪🇸 Transponder T33

Aumente su negocio de llaves de automoción con el nuevo transponder regrabable de cristal T33 de Silca, que le permitirá copiar los transponders tipo Megamos® Crypto (ID48-A e ID48-K) para los modelos de coche Chevrolet-Daewoo®, Kia® y Pontiac® más populares. El T33 representa una solución fiable y de alta calidad, CE marca certificada y garantizada por Silca.

### 🇧🇷 Transponder T33

Amplie o seu serviço chaves automotive com o novo transponder re-escrivível de vidro Silca T33, que lhe permitirá copiar transponder tipo Megamos® Crypto (ID48-A e ID48-K) para os modelos Chevrolet-Daewoo®, Kia® e Pontiac® mais difundidos. T33 é uma solução de confiança e de alta qualidade certificada com marca CE e garantida pela Silca.

### TRANSPONDER T33 - Uses

CAR MAKE	MODEL	YEAR		SILCA REFERENCE		
		FROM	TO	LOOK A-LIKE	FLIP	WITHOUT TRP
CHEVROLET-DAEWOO®	AVEO	2006	2011	DWO4RTE	DWO4RFH	DWO4RT6*
	KALOS	2002	2006	DWO4RTE	DWO4RFH	DWO4RT6*
	LANOS	2002	2004			
	LACETTI	2002	2004	DWO4RTE	DWO4RFH	DWO4RT6*
	LEGANZA	2000	2008	DWO5TE	DWO5FH	DWO5T6*
	MATIZ	2001	2005			DWO6BT6*
	MATIZ	2006				DWO4CT6*
	NUBIRA	2000	2002	DWO4RTE	DWO4RFH	DWO4RT6*
	NUBIRA	2002	2006			DWO4CT6*
TACUMA	2000	2008	DWO4RTE	DWO4RFH	DWO4RT6*	
KIA®	CARNIVAL	1999	2000	KIA3RTE	KIA3RFH	
	CLARUS	1998	2001	KIA3RTE	KIA3RFH	
	SEDONA	1999	2000	KIA3RTE	KIA3RFH	
	SHUMA	1998	2001	KIA3RTE	KIA3RFH	
	SPORTAGE	1999	2001	KIA3RTE	KIA3RFH	
	PRIDE	1999	2001	KIA3RTE	KIA3RFH	
PONTIAC®	G3	2006	2011	DWO4RTE	DWO4RFH	DWO4RT6*

\* You can order these key references without transponder and apply the transponder T33 later on. / È possibile ordinare la referenza indicata nella versione senza transponder e successivamente applicarvi il transponder T33. / Es kann die auf der Schlüsselversion ohne Transponder angegebene Artikelnummer bestellt und der Transponder T33 nachträglich eingesetzt werden. / Vous pouvez commander ces références de clés sans transpondeur et rajouter le transpondeur T33 ultérieurement. / Puede solicitar estas referencias de llaves sin transponder e insertar el transponder T33 después. / É possível encomendar a referência indicada na versão da chave sem transponder e em seguida aplicar o transponder T33. Chevrolet-Daewoo®, Kia®, Megamos® and Pontiac® are Registered Trademarks. / Chevrolet-Daewoo®, Kia®, Megamos® e Pontiac® sono Marchi Registrati. / Chevrolet-Daewoo®, Kia®, Megamos® und Pontiac® sind eingetragene Marken. / Chevrolet-Daewoo®, Kia®, Megamos® et Pontiac® sont des Marques Déposées. / Chevrolet-Daewoo®, Kia®, Megamos® y Pontiac® son Marcas Registradas. / Chevrolet-Daewoo®, Kia®, Megamos® e Pontiac® são Marcas Registradas.



## SILCA KEY PROGRAMS Web Update



[www.silca.biz](http://www.silca.biz)

### SILCA KEY PROGRAMS - **WEB Update**

A new update of the SILCA KEY PROGRAMS software is available to all WEB subscribers. Check out the "News" section of Silca Key Programs on [www.silca.biz](http://www.silca.biz) to know more.

### SILCA KEY PROGRAMS - **Aggiornamento WEB**

È disponibile un nuovo aggiornamento del software SILCA KEY PROGRAMS per tutti gli abbonati WEB. Consulta la sezione "Novità" di Silca Key Programs sul sito [www.silca.biz](http://www.silca.biz) per saperne di più.

### SILCA KEY PROGRAMS - **Aktualisierung WEB**

Für alle WEB Abonnenten ist eine neue Aktualisierung von der Software SILCA KEY PROGRAMS verfügbar. Sehen Sie den Abschnitt "Neuheiten" von Silca Key Programs auf [www.silca.biz](http://www.silca.biz), um weitere Informationen zu finden.

### SILCA KEY PROGRAMS - **Mise à jour WEB**

Une nouvelle mise à jour du logiciel SILCA KEY PROGRAMS pour tous les abonnements WEB est disponible. Consultez la section "Nouveautés" de Silca Key Programs sur notre site [www.silca.biz](http://www.silca.biz) pour en savoir plus.

### SILCA KEY PROGRAMS - **Actualización WEB**

Una nueva actualización del software SILCA KEY PROGRAMS para todos los abonados WEB está disponible. Visite la sección "Novedades" de Silca Key Programs en el sitio [www.silca.biz](http://www.silca.biz) para más informaciones.

### SILCA KEY PROGRAMS - **Atualização WEB**

Nova atualização do software SILCA KEY PROGRAMS para todos o assinantes WEB está disponível. Consulte a seção "Novidades" de Silca Key Programs no site [www.silca.biz](http://www.silca.biz) para saber mais.

**More info on [www.silca.biz](http://www.silca.biz)**





## ELF Convention 2014

**UK** A very successful convention in which Silca participated as an exhibitor and Silver Sponsor and that was the opportunity to celebrate the 30<sup>th</sup> anniversary of the European Locksmith Association.

**IT** Una convention di grande successo a cui Silca ha partecipato quale espositore e Silver Sponsor e che è stata l'occasione di festeggiare il trentennale dell'Associazione dei Locksmith Europei.

**DE** Ein erfolgreicher Kongress, an dem Silca als Aussteller und Silver Sponsor teilgenommen hat. Er war auch die Gelegenheit, den 30. Jahrestag des Verbandes europäischer Schlosser zu feiern.

**FR** Une convention très réussie à laquelle Silca a participé comme exposant et Silver Sponsor et qui a été l'occasion pour célébrer le trentième anniversaire de la Fédération Européenne Serruriers.

**ES** Una convención de gran éxito en la que Silca participó como expositor y Silver Sponsor y que fue la ocasión para celebrar el trigésimo aniversario de la Federación Europea de Cerrajeros.

**PT** Uma convenção muito bem sucedida em que Silca participou como expositor e Silver Sponsor e essa foi a oportunidade para celebrar o 30º aniversário da Federação Europeia Serralheiros.

### Facts and Figures / Fatti e Cifre / Zahlen und Fakten / Faits et Chiffres / Datos y Cifras / Fatos e Números

## 24

**represented locksmith associations** / associazioni di settore rappresentate / vertrete Schlosserverbände / associations de serruriers représentées / asociaciones de cerrajeros representadas / associações de serralheiros representadas

## 1900

**registered visitors, a third of whom foreigners** / visitatori registrati, un terzo dei quali stranieri / registrierte Besucher, ein Drittel von ihnen Ausländer / visiteurs inscrits, dont un tiers étrangers / visitantes registrados, un tercio de ellos extranjeros / visitantes registrados, um terço deles estrangeiros

## 170

**training classes participants** / partecipanti ai corsi a pagamento / Teilnehmer an den Schulungen / participants aux cours de formation / participantes en los cursos de formación / participantes dos cursos de formação

## 45

**visitors' countries of origin** / paesi di provenienza dei visitatori / Herkunftsländer der Besucher / pays d'origine des visiteurs / países de origen de los visitantes / países de origem dos visitantes

## 40

**exhibitors** / espositori / Aussteller / exponents / expositores / expositores

## 30

**years of activity of ELF** / anni di attività dell'ELF / Jahre von ELF Aktivität / années d'activité de ELF / años de actividad del ELF / anos de atividade da ELF

Full ELF Convention 2014 photogallery on [www.silca.biz](http://www.silca.biz)